



CAMPANAS

CAMPANA EXTRACTORA GARÓS

Código Artículo: CGA
17.05.2018

INFORMACIÓN TÉCNICA

Aplicaciones	Extracción de humos para cocinas industriales.
Formato	Mural o central.
Construcción	Campana totalmente soldada en una sola pieza hasta 7M.
Material	Chapa de acero inoxidable AISI 304 de 1 mm de grosor.
Acabados	Plenum de aportación incorporado con aislante y punzonado frontal. Estructura tubular y partes no vistas en acero galvanizado. Doble plegado en todos los finales de chapa. Sin tornillos ni rebordes extraños.
Recogegrasas	Perimetral conectado a la bandeja inferior.
Filtros	Filtros de placas inox AISI 430.

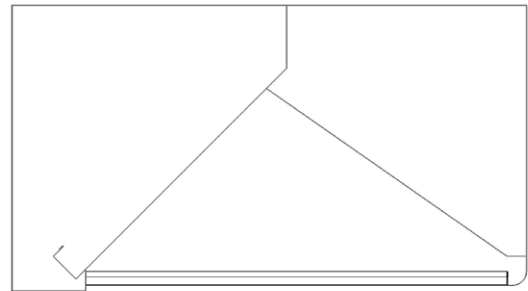

MODELOS

Modelo	Altura (H)	Filtros
Garòs 4	390 mm	490X400X50
Garòs 5	500 mm	490X490X50
Garòs 6	610 mm	490X490X50

NORMATIVAS

Certificado de construcción: N^o 023889AA del 6/10/2005 emitido por el Colegio de Ingenieros Técnicos Industriales de Barcelona.

Diseño y fabricación: Directrices de las normas CTEo6 y UNE 100-165-04.

Clasificación al Fuego: A1.

OPCIONALES



MORGUICLIMA, S.L. se reserva el derecho de modificar sus productos y precios sin previo aviso. La garantía sólo cubre productos no utilizados y sin defectos causados por usos indebidos u ocasionados por el transporte.



CAMPANAS

CAMPANA EXTRACTORA GARÓS

Código Artículo: CGA
17.05.2018

MEDIDAS

MURAL GARÓS 4

Fondo 900	A	Kg*	Filtros	m³/h	∅Cond.**
1.050	-	42	2	1.700	250
1.500	-	55	3	2.400	300
2.000	-	76	4	2.900	315
2.500	-	90	5	3.650	355
3.000	-	105	6	4.375	400
3.500	-	126	7	4.650	400
4.000	-	145	8	5.310	450
4.500	-	160	9	5.975	450
5.000	-	177	10	6.650	500

Fondo 1.100	A	Kg*	Filtros	m³/h	∅Cond.**
1.050	-	45	2	2.080	250
1.500	-	62	3	2.675	300
2.000	-	83	4	3.560	315
2.500	-	99	5	4.455	355
3.000	-	115	6	4.870	400
3.500	-	138	7	5.680	400
4.000	-	160	8	6.500	450
4.500	-	177	9	7.300	450
5.000	-	195	10	8.100	500

MURAL GARÓS 5 y 6

Fondo 900	Kg* G5	Kg* G6	Filtros	m³/h	∅Cond.**
1.050	47	49	2	1.700	250
1.500	62	65	3	2.400	300
2.000	84	88	4	2.900	315
2.500	99	104	5	3.650	355
3.000	111	116	6	4.375	400
3.500	135	142	7	4.650	400
4.000	153	160	8	5.310	450
4.500	170	178	9	5.975	450
5.000	186	195	10	6.650	500

Fondo 1.100	Kg* G5	Kg* G6	Filtros	m³/h	∅Cond.**
1.050	50	52	2	2.080	250
1.500	66	69	3	2.675	300
2.000	88	92	4	3.560	315
2.500	105	110	5	4.455	355
3.000	122	128	6	4.870	400
3.500	145	152	7	5.680	400
4.000	166	174	8	6.500	450
4.500	185	194	9	7.300	450
5.000	204	214	10	8.100	500

* Peso neto de las campanas sin accesorios (luminarias, filtros y controles).
** Diámetro de conducto recomendado.

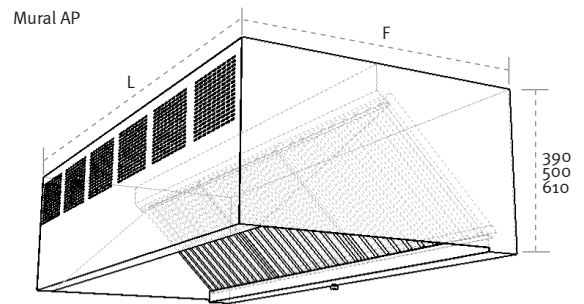
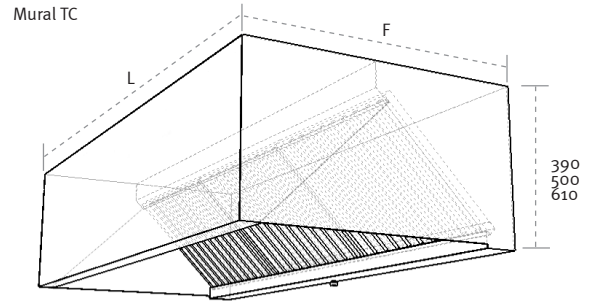

LEYENDA

L	Longitud	TC	Techo cerrado
F	Fondo	AP	Aportación
H	Altura campana	RG	Regulación
A	Altura plenum	PL	Plenum



CAMPANAS

CAMPANA EXTRACTORA GARÓS

Código Artículo: CGA
17.05.2018

MEDIDAS

CENTRAL GARÓS 4

Fondo 1.500		Kg*	Filtros	m³/h	∅Cond.**
2.000	-	121	8	6.300	400
2.500	-	138	10	7.200	450
3.000	-	166	12	8.100	500
3.500	-	195	14	9.000	560
4.000	-	218	16	9.900	560
4.500	-	241	18	10.800	630
5.000	-	266	20	11.700	630

Fondo 2.200		Kg*	Filtros	m³/h	∅Cond.**
2.000	-	160	8	7.560	400
2.500	-	195	10	8.460	450
3.000	-	229	12	9.360	500
3.500	-	265	14	10.260	560
4.000	-	297	16	11.160	560
4.500	-	347	18	12.050	630
5.000	-	378	20	12.950	630

CENTRAL GARÓS 5 y 6

Fondo 1.500	Kg* G5	Kg* G6	Filtros	m³/h	∅Cond.**
2.000	127	133	8	6.300	400
2.500	143	150	10	7.200	450
3.000	172	180	12	8.100	500
3.500	201	211	14	9.000	560
4.000	226	237	16	9.900	560
4.500	250	262	18	10.800	630
5.000	276	289	20	11.700	630

Fondo 2.200	Kg* G5	Kg* G6	Filtros	m³/h	∅Cond.**
2.000	165	173	8	7.560	400
2.500	195	205	10	8.460	450
3.000	234	245	12	9.360	500
3.500	272	285	14	10.260	560
4.000	305	320	16	11.160	560
4.500	354	371	18	12.050	630
5.000	388	407	20	12.950	630

* Peso neto de las campanas sin accesorios (luminarias, filtros y controles).
** Diámetro de conducto recomendado.

LEYENDA

L	Longitud	TC	Techo cerrado
F	Fondo	AP	Aportación
H	Altura campana	RG	Regulación
A	Altura plenum	PL	Plenum

Central TC

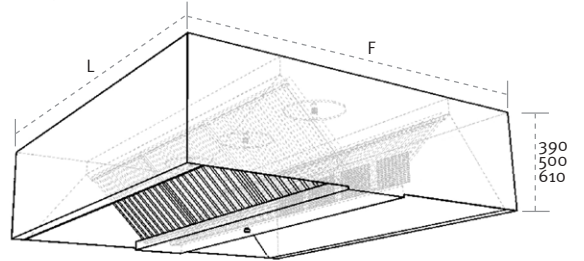

Central AP

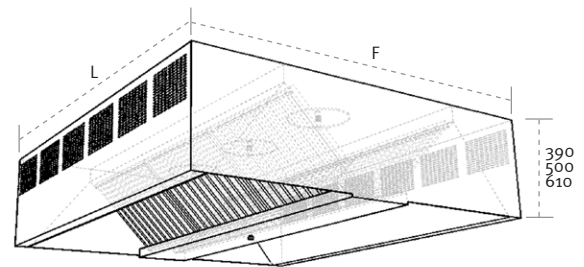

MORGUICLIMA, S.L. se reserva el derecho de modificar sus productos y precios sin previo aviso. La garantía sólo cubre productos no utilizados y sin desperfectos causados por usos indebidos u ocasionados por el transporte.

